

Product Data Sheet 412/2

ebmpapst

Die Wahl der Ingenieure



412/2

INDEX

1	General	3
2	Mechanics	3
2.1	General	3
2.2	Connections	3
3	Operating Data	4
3.1	Operating Data - Electrical Interface - Input	4
3.2	Electrical Operating Data	5
3.3	Operating Data - Electrical Interface - Output	6
3.4	Electrical Features	7
3.5	Aerodynamics	8
3.6	Sound Data	8
4	Environment.....	9
4.1	General	9
4.2	Climatic Requirements*)	9
5	Safety.....	10
5.1	Electrical Safety	10
5.2	Approval Tests	10
6	Reliability.....	10
6.1	General	10

1 General

Fan type	Fan	
Rotating direction looking at rotor	Counterclockwise	
Airflow direction	Air outlet over struts	
Bearing system	Sleeve bearing	
Mounting position	Any	

2 Mechanics

2.1 General

Width	40,0 mm	
Height	40,0 mm	
Depth	20,0 mm	
Mass	0,027 kg	
Housing material	Plastic	
Impeller material	Plastic	
Max. torque when mounted across both mounting flanges	wire outlet corner: 80 Ncm remaining corners: 90 Ncm	
Screw size	ISO 4762 - M4 degreased, without an additional brace and without washer	

2.2 Connections

Electrical connection	Wires	
Lead wire length	L = 310 mm	
Tolerance	+/- 10,0 mm	
Wire size (AWG)	28	
Insulation diameter	1,40 mm	
Contact	See drawing	

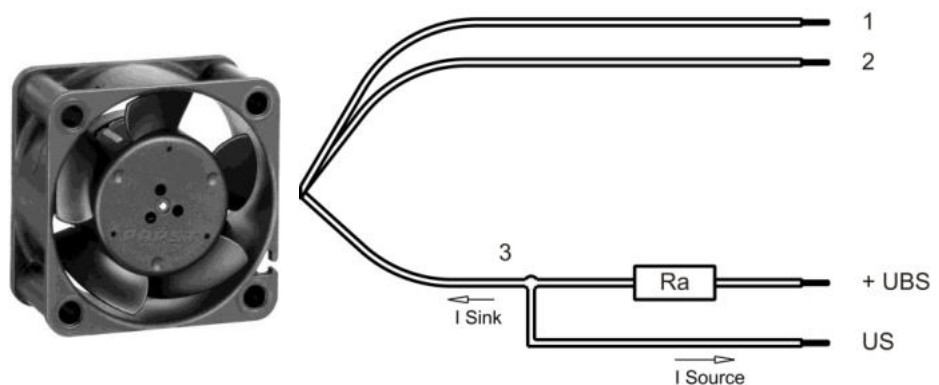

	Colour	Operation
Wire 1	red	+ UB
Wire 2	blue	- GND
Wire 3	white	Tacho

The auxiliaries shown on the schematic diagram (which are required for the intended use) are not part of our delivery.

3 Operating Data

3.1 Operating Data - Electrical Interface - Input

Control input	None
---------------	------

3.2 Electrical Operating Data

Measurement conditions: Normal air density = 1,2 kg/m³; Temperature 23°C +/- 3°C; Motor axis horizontal; warm-up time before measuring 5 minutes (unless otherwise specified). In the intake and outlet area should not be any solid obstruction within 0,5 m.

$\Delta p = 0$: corresp. to free air flow (see section 3.5)
 I: corresp. to arithm. mean current value

Features	Condition	Symbol	Values		
Voltage range	$\Delta p = 0$	U	10,0 V		14,0 V
Nominal voltage	$\Delta p = 0$	U_N		12,0 V	
Power consumption	$\Delta p = 0$	P	0,5 W	0,8 W	1,0 W
Tolerance	0001		+/- 17,5 %	+/- 12,5 %	+/- 17,5 %
Current consumption	$\Delta p = 0$	I	50 mA	63 mA	70 mA
Tolerance	0001		+/- 17,5 %	+/- 12,5 %	+/- 17,5 %
Speed	$\Delta p = 0$	n	4.750 1/min	6.000 1/min	6.800 1/min
Tolerance	0001		+/- 15,0 %	+/- 10,0 %	+/- 15,0 %
Starting current consumption				140 mA	

3.3 Operating Data - Electrical Interface - Output

Tacho type	/2 (open collector)
------------	---------------------

Signal-Ausgangsspannung / Signal output voltage

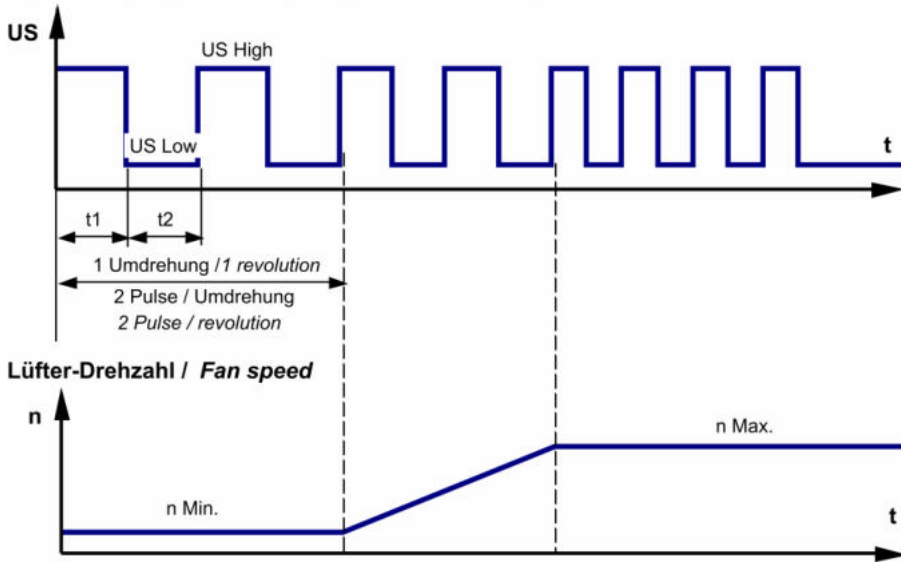

$$R_a = \frac{U_{BS} - US_{Low}}{I_{Sink}}$$

Features	Note	Values
Tacho operating voltage (UBS)		$\leq 30\text{ V}$
Tacho signal Low	$I_{sink}: 1\text{ mA}$	$\leq 0,4\text{ V}$
Tacho signal High	$I_{source}: 0\text{ mA}$	$\leq 30\text{ V}$
Maximum sink current		$\leq 2\text{ mA}$
External resistor	External resistor R_a from UBS to US required. All voltages measured to GND.	
Tacho frequency	$(2 \times n) / 60$	
Tacho isolated from motor	No	
Slew rate		$\Rightarrow 0,5\text{ V/us}$

3.4 Electrical Features

Electronic function	None	
Reversed polarity protection	Rectifying diode	
Max. residual current at U_n	$I_F \leq 30 \text{ nA}$	
Locked rotor protection	Impedance protected	
Locked rotor current at U_n		

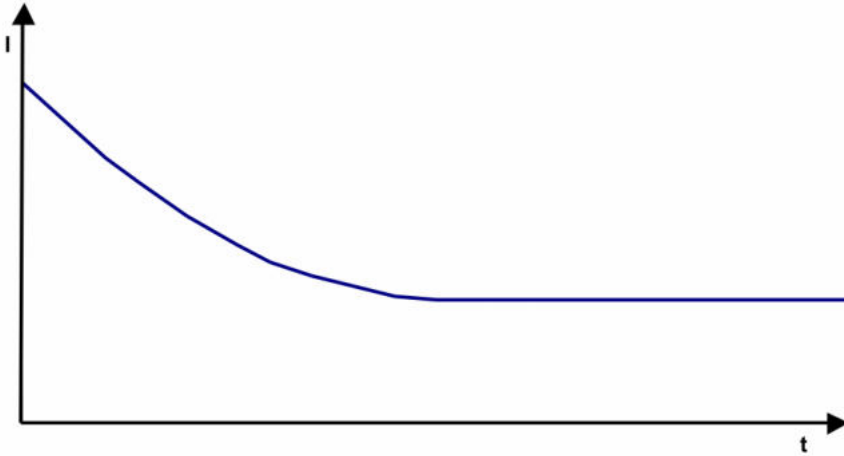

3.5 Aerodynamics

Measurement conditions: Measured with a double chamber intake rig.
 Normal air density = 1,2 kg/m³; Temperature 23°C +/- 3°C;
 In the intake and outlet area should not be any solid obstruction within 0,5 m.
 The information is only valid under the specified test conditions and may be changed by the installation conditions. If there are deviations from the standard test conditions, the characteristic values must be checked under the installed conditions.

a.) Operation condition:

6.000 1/min at free air flow		
Max. free-air flow ($\Delta p = 0 / \dot{V} = \text{max.}$)	10,0 m ³ /h	
Max. static pressure ($\Delta p = \text{max.} / \dot{V} = 0$)	41 Pa	

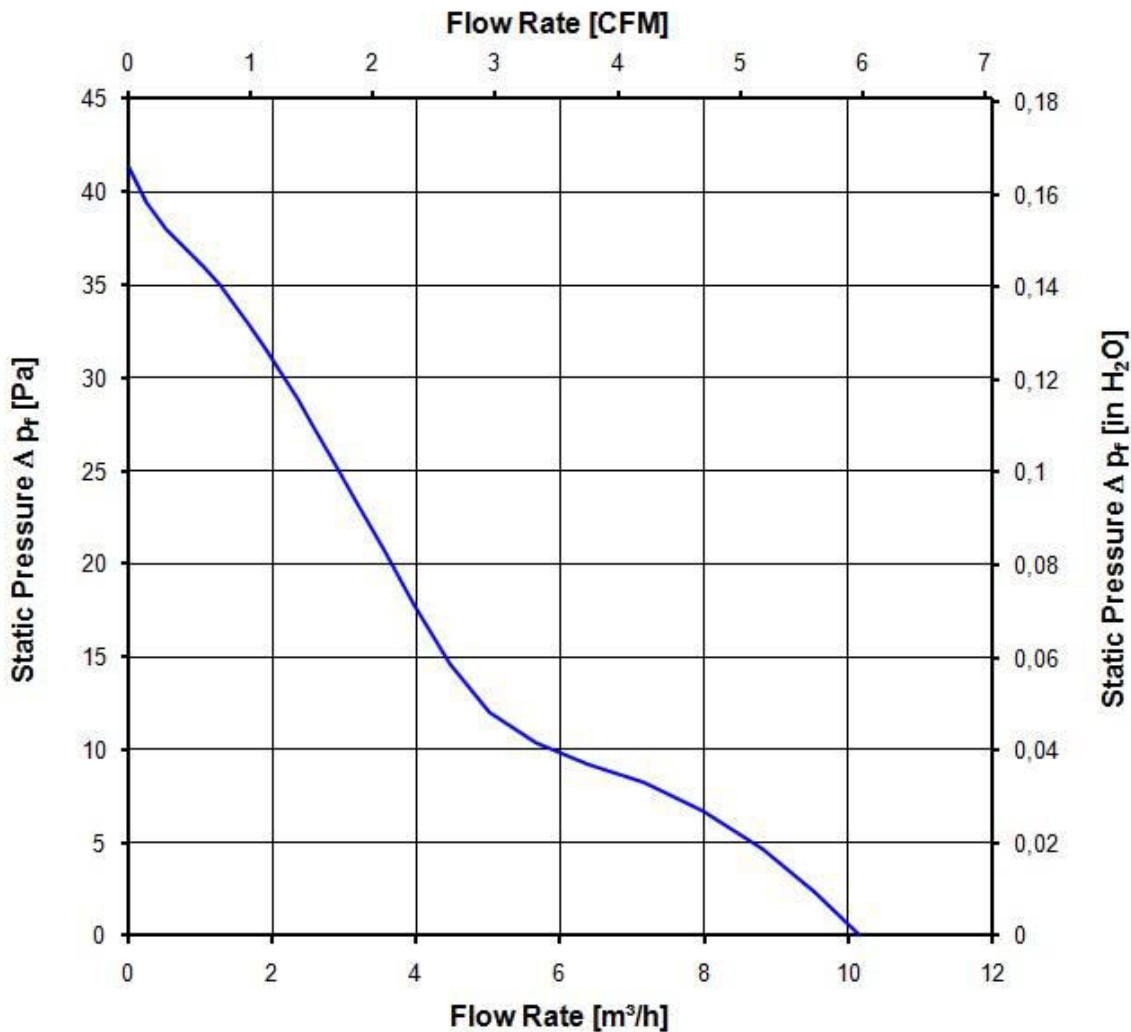

3.6 Sound Data

Measurement conditions: Sound pressure level: 1 Meter distance between microphone and the air intake.
 Sound power level: Acc. to DIN 45635 part 38 (ISO 10302)

Measured in a semianchoic chamber with a background noise level of $L_p(A) < 5 \text{ dB(A)}$
 For further measurement conditions see section 3.5

a.) Operation condition:

6.000 1/min at free air flow		
Optimal operating point	9,0 m ³ /h @ 5 Pa	
Sound power level at the optimal operating point	4,1 bel(A)	
Sound pressure level at free air flow, measured in rubber bands	20,0 dB(A)	

4 Environment

4.1 General

Min. permitted ambient temperature TU min.	-20 °C	
Max. permitted ambient temperature TU max.	70 °C	
Min. permitted storage temperature TL min.	-40 °C	
Max. permitted storage temperature TL max.	80 °C	

4.2 Climatic Requirements *)

Humidity requirements	humid heat, constant; according to DIN EN 60068-2-78, 14 days	
Water exposure	None	
Dust requirements	None	
Salt fog requirements	None	

*) Permitted application area:

The product is intended for use in sheltered rooms with controlled temperature and controlled humidity. Directly exposure to water must be avoided.

Pollution degree 1 (according DIN EN 60664-1)

There is either no pollution or it occurs only dry, non-conductive pollution. The pollution has no negative impact. Please require severity levels and specification parameters from the responsible development departments

5 Safety

5.1 Electrical Safety

Dielectric strength DIN EN 60950 (VDE 0805) and DIN EN 60335 (VDE 0700) A.) Type test Measuring conditions: After 48h of storage at 95% R.H. and 25°C. No arcing or breakdown is allowed! All connections together to ground.	Not applicable	
B.) Routine test Measuring conditions: At indoor climate. No arcing or breakdown is allowed! All connections together to ground.	Not applicable	
Isolation resistance Measuring conditions: After 48h of storage at 95% R.H. and 25°C measured with U=500 VDC for 1 min.	RI > 10 MOhm	
clearance / creepage distance	1,0 mm / 1,2 mm	
Protection class	III	

5.2 Approval Tests

CE	EC Declaration of Conformity	Yes
EAC	Eurasian Conformity	Yes
UL	Underwriters Laboratories	Yes / UL507, Electric Fans
VDE	Association for Electrical, Electronic and Information Technologies	Yes / Approval acc. to EN 60950 (VDE 0805) - Information technology equipment
CSA	Canadian Standards Association	Yes / C22.2 No. 113 Fans and Ventilators
CCC	China Compulsory Certification	No

6 Reliability

6.1 General

Life expectancy L10 at TU = 20 °C	50.000 h	
Life expectancy L10 at TU = 40 °C	35.000 h	
Life expectancy L10 at TU = 60 °C	20.000 h	
Life expectancy L10 at TU max.	15.000 h	

Copying of this document, and giving it to others and the use or communication of the contents thereof, are prohibited. In the event of a breach, the copyright holder reserves all rights. All rights are reserved.
 Schutzzweck nach DIN ISO 9015 beachten/
 Refer to protection note DIN ISO 9015!

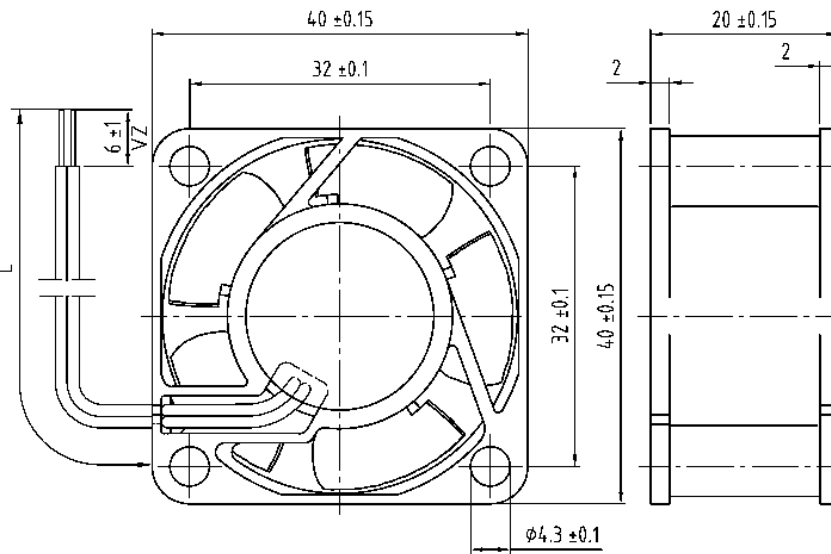

⊙ Anzahl und Länge der Litzen siehe Spezifikationsdaten
 length and number of wires see design specification

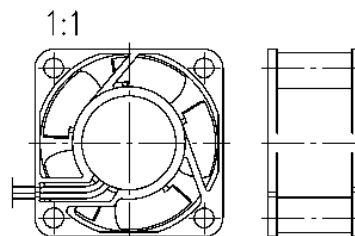

UV = unverzinkt / not tin plated
 VZ = verzinkt / tin plated
 AV = angeschnitten u. vorgezogen / truncated and pulled

SAP-Status/State		Amd.-Nr./Change-No.		AutCAD-System-Version		Date/Date		Name/Name		Werkstoff/Material:		Volumen / Volume [mm ³]:	
Bereit / Drawn		Gepr. / Checked		Freig. / Released		Artikel / Title		Zchg.-Nr. / Drawing-No.:		Ers./Zchg. / Replaces:		Gewicht / Mass [g]:	
Tolerierung/Tolerances		Allgemeintoleranzverf./Gen. tolerances:				Zchg.-Nr. / Drawing-No.:		Ers./Zchg. / Replaces:				Document/Type of Document Teil/Element (Sheet/Page) Info/Index Form#/Site Messstab/Scale	
ebm-papst St. Georgen GmbH & Co. KG													