

Product Data Sheet 4114 N/2H4

**ebmpapst**

The engineer's choice



## 4114 N/2H4

## INDEX

<b>1</b>	<b>General</b> .....	<b>3</b>
<b>2</b>	<b>Mechanics</b> .....	<b>3</b>
2.1	General.....	3
2.2	Connections.....	3
<b>3</b>	<b>Operating Data</b> .....	<b>4</b>
3.1	Electrical Operating Data .....	4
3.2	Electrical Interface - Output.....	5
3.3	Electrical Features .....	5
3.4	Aerodynamics .....	7
3.5	Sound Data.....	8
<b>4</b>	<b>Environment</b> .....	<b>8</b>
4.1	General.....	8
4.2	Climatic Requirements .....	8
4.3	EMC .....	8
<b>5</b>	<b>Safety</b> .....	<b>10</b>
5.1	Electrical Safety .....	10
5.2	Approval Tests.....	10
<b>6</b>	<b>Reliability</b> .....	<b>10</b>
6.1	General.....	10

## 1 General

Fan type	Fan	
Rotating direction looking at rotor	Clockwise	
Airflow direction	Air intake over struts	
Bearing system	Ball bearing	
Mounting position - shaft	Any	

## 2 Mechanics

### 2.1 General

Width	119,0 mm	
Height	119,0 mm	
Depth	38,0 mm	
Mass	0,390 kg	
Housing material	Metal	
Impeller material	Plastic	
Max. torque when mounted across both mounting flanges	Wire outlet corner: 420 Ncm Remaining corners: 560 Ncm	
Screw size	ISO 4762 - M4 degreased, without an additional brace and without washer	

### 2.2 Connections

Electrical connection	Wires	
Lead wire length	L = 310 mm	
Tolerance	+ - 10,0 mm	

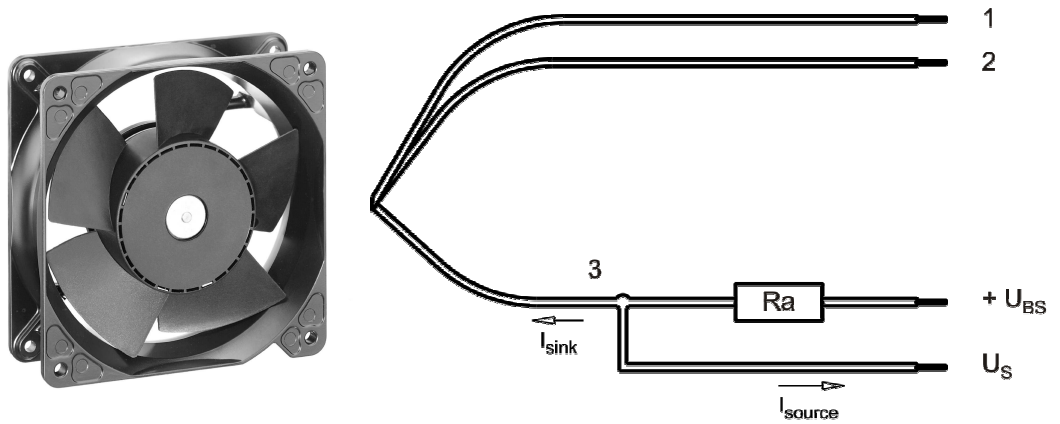

Wire	Color	Operation	Wire size	Insulation diameter
1	red	+ UB	AWG 22	1,7 mm
2	blue	- GND	AWG 22	1,7 mm
3	white	Tacho	AWG 22	1,7 mm

The auxiliaries shown on the schematic diagram (which are required for the intended use) are not part of our delivery.

### 3 Operating Data

#### 3.1 Electrical Operating Data

Measurement conditions: Normal air density = 1,2 kg/m<sup>3</sup>; Temperature 23°C +/- 3°C; Motor axis horizontal; warm-up time before measuring 5 minutes (unless otherwise specified). In the intake and outlet area should not be any solid obstruction within 0,5 m.

$\Delta p = 0$ : corresp. to free air flow (see chapter aerodynamics)  
I: corresp. to arithm. mean current value

**Note:**

**No inrush current at Unom means:**

The internal electrolytic capacitor 120uF/50V has no resistor or inrush current limitation, essentially the power supply and the type and length of the connecting cable is limiting the Inrush current.

Features	Condition	Symbol	Values		
			16 V	24 V	30 V
Voltage range		U	16 V		30 V
Nominal voltage		U <sub>N</sub>		24 V	
Power consumption	$\Delta p = 0$	P	15,2 W	30 W	30,0 W
Tolerance	0010		+/- 15 %	+/- 15 %	+/- 15 %
Current consumption	$\Delta p = 0$	I	950 mA	1.250 mA	1.000 mA
Tolerance	0010		+/- 15 %	+/- 15 %	+/- 15 %
Speed	$\Delta p = 0$	n	5.400 1/min	6.800 1/min	6.800 1/min
Tolerance	0010		+/- 10 %	+/- 10 %	+/- 10 %
Starting current consumption				3.200 mA	

### 3.2 Electrical Interface - Output

Tacho type	/2 (open collector)
------------	---------------------



Features	Note	Values
Tacho operating voltage	$U_{BS}$	60 V
Tacho signal Low	$U_{S\ low}$	$\leq 0,5\ V$
Tacho signal High	$U_{S\ high}$	60 V
Maximum sink current	$I_{sink}$	$\leq 10\ mA$
External resistor	External resistor $R_a$ from $U_{BS}$ to $U_S$ required. All voltages measured to GND.	
Tacho frequency	$(2 \times n) / 60$	
Tacho isolated from motor	No	

n = revolutions per minute (1/min)

### 3.3 Electrical Features

Electronic function	Speed-Controlled	
Reversed polarity protection	Rectifying diode	
Max. residual current at $U_N$	$I_F \leq 10\ mA$	
Locked rotor protection	Auto restart	
Locked rotor current at $U_N$	$I_{block}$ approx. 3.200 mA	
Clock signal at locked rotor	$t_3 / t_4$ typical: 1,0 s / 5,5 s	

**Internal Fuse:**

Littlefuse NANO2(R) FUSE; Very fast acting 451 Series; 3 A (Art.-Nr.: 451003)

### 3.4 Aerodynamics

Measurement conditions:

Measured with a double chamber intake rig acc. to DIN EN ISO 5801.

Normal air density = 1,2 kg/m<sup>3</sup>; Temperature 23°C +/- 3°C;

In the intake and outlet area should not be any solid obstruction within 0,5 m. Motor shaft horizontal.

The information is only valid under the specified test conditions and may be changed by the installation conditions. If there are deviations from the standard test conditions, the characteristic values must be checked under the installed conditions.

a.) Operation condition:

6.800 1/min at free air flow

Max. free-air flow ( $\Delta p = 0 / \dot{V} = \text{max.}$ )	350,0 m <sup>3</sup> /h	
Max. static pressure ( $\Delta p = \text{max.} / \dot{V} = 0$ )	400 Pa	

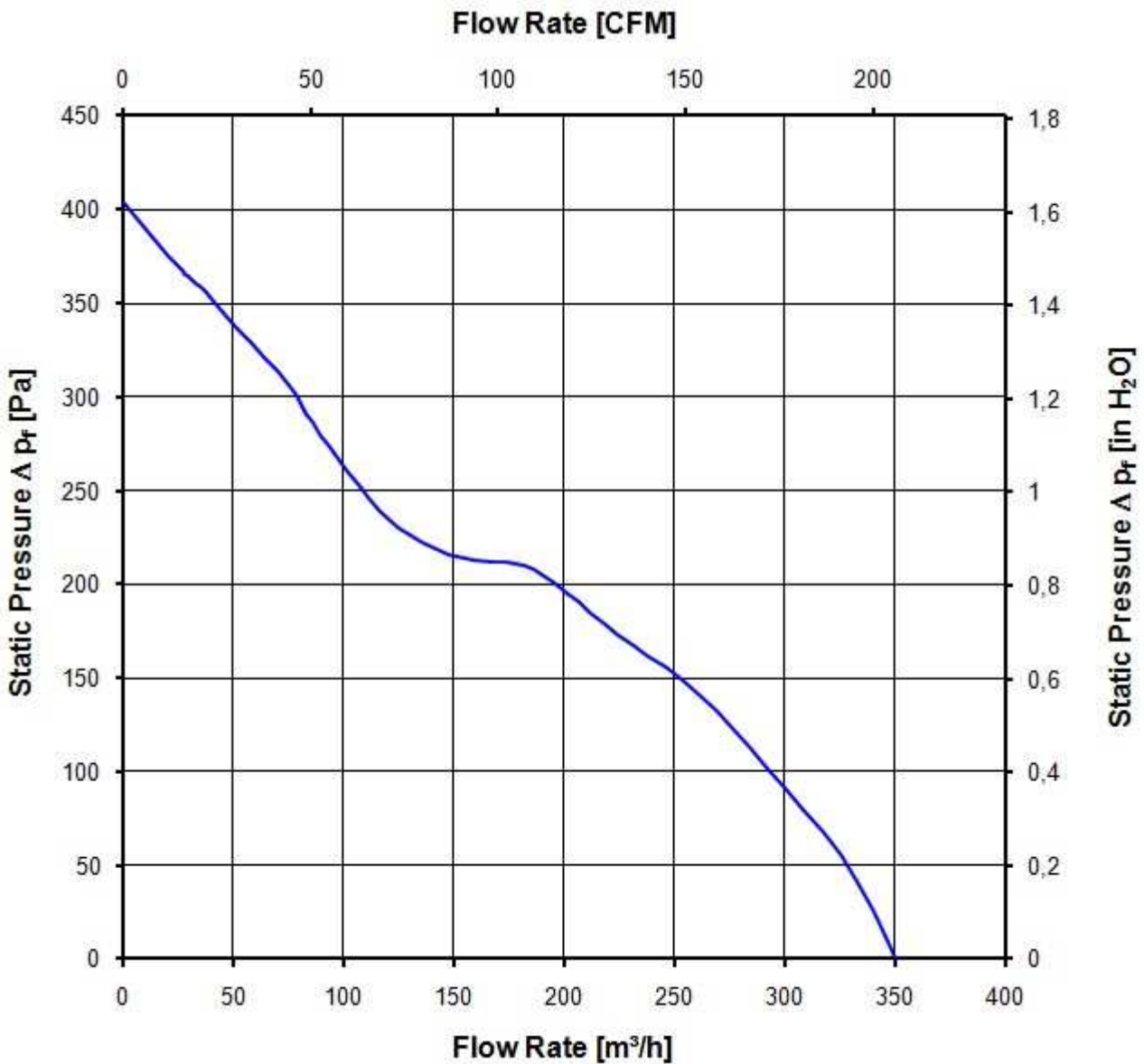

### 3.5 Sound Data

Measurement conditions: Sound pressure level: 1 meter distance between microphone and the air intake.  
 Sound power level: Acc. to DIN 45635 part 38 (ISO 10302)  
 Measured in a semianchoic chamber with a background noise level of  $L_p(A) < 5 \text{ dB(A)}$   
 For further measurement conditions see chapter aerodynamics.

a.) Operation condition:

6.800 1/min at free air flow
------------------------------

Optimal operating point	250,0 m3/h @ 140 Pa	
Sound power level at the optimal operating point	7,4 bel(A)	
Sound pressure level at free air flow, measured in rubber bands	67,0 dB(A)	

## 4 Environment

### 4.1 General

Min. permitted ambient temperature TU min.	-20 °C	
Max. permitted ambient temperature TU max.	65 °C	
Min. permitted storage temperature TL min.	-40 °C	
Max. permitted storage temperature TL max.	80 °C	

### 4.2 Climatic Requirements

Humidity requirements	humid heat, constant; according to DIN EN 60068-2-78, 14 days	
Water exposure	None	
Dust requirements	None	
Salt fog requirements	None	

Permitted application area:

The product is intended for use in sheltered rooms with controlled temperature and controlled humidity. Directly exposure to water must be avoided.

Pollution degree 1 (according DIN EN 60664-1)

There is either no pollution or it occurs only dry, non-conductive pollution. The pollution has no negative impact.

Please require severity levels and specification parameters from the responsible development departments.

### 4.3 EMC

<b>Kind</b>	<b>Radiated Emission; 30 MHz - 1000 MHz</b>
According	DIN EN 55032:2016-02
Check accuracy / Limit	Class B
Result	Below limit Class B



<b>Kind</b>	<b>Electrostatic Discharge Immunity Test</b>
According	DIN EN 61000-4-2:2001-12
Check accuracy / Limit	Contact Discharge +/- 4 kV; Air Discharge +/- 8 kV
Result	B: The monitored function may deviate from designed performance to a specified level during exposure to a disturbance or revert to a fail safe mode or operation, but shall return to normal operation after the disturbance is removed.

**5 Safety**

**5.1 Electrical Safety**

Dielectric strength DIN EN 60950 (VDE 0805) and DIN EN 60335 (VDE 0700) A.) Type test Measuring conditions: After 48h of storage at 95% R.H. and 25°C. No arcing or breakdown is allowed! All connections together to ground.	500 VAC / 1 Min.	
B.) Routine test Measuring conditions: At indoor climate. No arcing or breakdown is allowed! All connections together to ground.	850 VDC / 1 Sec.	
Isolation resistance Measuring conditions: After 48h of storage at 95% R.H. and 25°C measured with U=500 VDC for 1 min.	RI > 10 MOhm	
Clearance / creepage distance	1,0 mm / 1,2 mm	
Protection class	III	

**5.2 Approval Tests**

CE	EC Declaration of Conformity	Yes
EAC	Eurasian Conformity	Yes
UL	Underwriters Laboratories	Yes / UL507, Electric Fans
VDE	Association for Electrical, Electronic and Information Technologies	Yes / Approval acc. to EN 60950 (VDE 0805) - Information technology equipment
CSA	Canadian Standards Association	Yes / C22.2 No. 113 Fans and Ventilators
CCC	China Compulsory Certification	Not applicable

The approval tests are observed to:

U approval max.:30,0 V @ TU approval max.: 65,0 °C

**6 Reliability**

**6.1 General**

Life expectancy L10 at TU = 40 °C	62.500 h	
Life expectancy L10 at TU max.	35.000 h	
Life expectancy L10 acc. to IPC 9591 at TU = 40 °C	105. 000 h	

Copying of this document, and giving it to others and the use or communication of the contents thereof, are forbidden without express authority. Offenders are liable to the payment of damages. All rights are reserved in the event of the grant of a patent or the registration of a utility model or design.

Schutzmerk nach DIN ISO 1676 beachtend  
 Refer to protection notice DIN ISO 1676

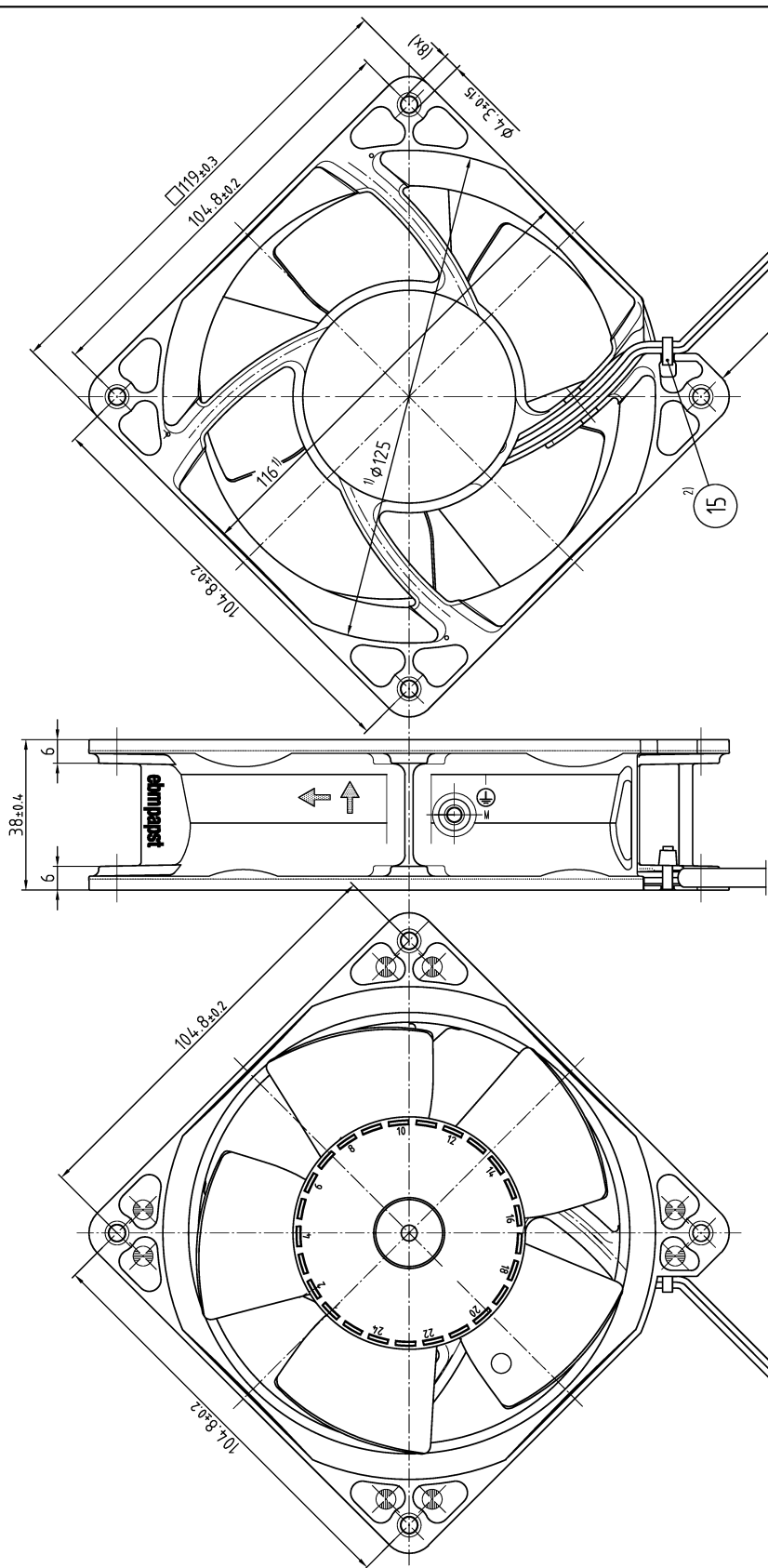

- 1) = Maße für Montagewand
- Axialspiel bei Kugellagerung (K) : 0 (durch Federausgleich)
- Axialspiel bei Gleitlagerung (G) : 0,1 bis 0,6
- 2) = Mit Handhabungswerkzeug montieren.

Kopf darf nach Montage nicht über Außenkontur des Lüftergehäuses stehen

- 1) = Measures for prefab wall
  - Axial play with ball bearing (K) : 0 (by spring compensation)
  - Axial play with sleeve bearing (G) : 0,1 to 0,6
  - 2) = With handling tool installed,
- Head may not stand over outer contour of the fan housing after assembly

Leitungslänge siehe Produktspezifikation  
 For conduit length see product specification

SP-Symbol/Date	Best.-Nr./Change-No.	Artikelnr./Spre-Nr./Teil-Name	Werkstoff/Material	Volumen/Volume (mm <sup>3</sup> )
		ebmpapst CAD-Eingabe CAD-Export/COMET		Gewicht/Mass (g)
Tolerierung/Tolerances		Bezeichnung Name/Name	Artikel/Title	
Allgemeintoleranzen/Tolerances		Beinh./ Clean		
DIN ISO 2768-1 u. 2-mK		Engl./ Release	axial compact fan	
		Zug-/Nr./Drawing-No.	Ers./Zug./Replaces	
		Diameter/Type of Mount	Teilnr./No.	Maßstab/Scale
		ebmpapst St. Georgen GmbH & Co. KG	Teilname/Part/Part	