

Product Data Sheet

9693520186

VWC0092JUGCS

3218 J/2H4P

ebmpapst

The engineer's choice



3218 J/2H4P

INDEX

- 1 General 3**
- 2 Mechanics 3**
 - 2.1 General..... 3
 - 2.2 Connections..... 3
- 3 Operating Data 4**
 - 3.1 Electrical Interface - Input..... 4
 - 3.2 Electrical Operating Data 5
 - 3.3 Electrical Interface - Output..... 6
 - 3.4 Electrical Features 7
 - 3.5 Aerodynamics 8
 - 3.6 Sound Data..... 9
- 4 Environment..... 9**
 - 4.1 General..... 9
 - 4.2 Climatic Requirements 9
- 5 Safety..... 10**
 - 5.1 Electrical Safety 10
 - 5.2 Approval Tests 10
- 6 Reliability..... 10**
 - 6.1 General..... 10

1 General

Fan type	Fan	
Rotating direction looking at rotor	Clockwise	
Airflow direction	Air outlet over struts	
Bearing system	Ball bearing	
Mounting position - shaft	Any	

2 Mechanics

2.1 General

Width	92,0 mm	
Height	92,0 mm	
Depth	38,0 mm	
Mass	0,280 kg	
Housing material	Plastic	
Impeller material	Plastic	
Max. torque when mounted across both mounting flanges	Wire outlet corner: 30 Ncm Remaining corners: 30 Ncm	
Screw size	ISO 4762 - M4 degreased, without an additional brace and without washer	

2.2 Connections

Electrical connection	Wires	
Lead wire length	L = 310 mm	
Tolerance	+ - 10,0 mm	

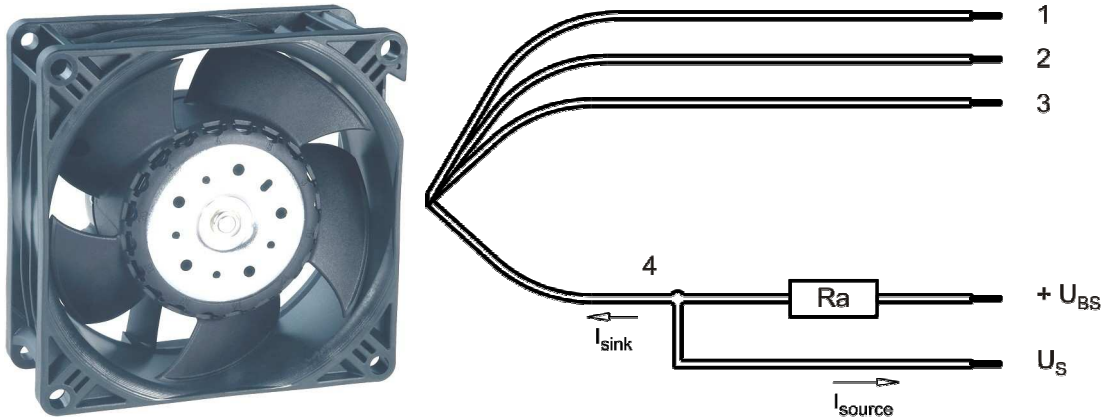

Wire	Color	Operation	Wire size	Insulation diameter
1	red	+ UB	AWG 22	1,30 mm
2	blue	- GND	AWG 22	1,30 mm
3	violet	PWM	AWG 22	1,30 mm
4	white	Tacho		

The auxiliaries shown on the schematic diagram (which are required for the intended use) are not part of our delivery.

3 Operating Data

3.1 Electrical Interface - Input

Control input	PWM
---------------	-----

Features

Input type	Open collector	
PWM - Frequency		1 kHz - 5 kHz

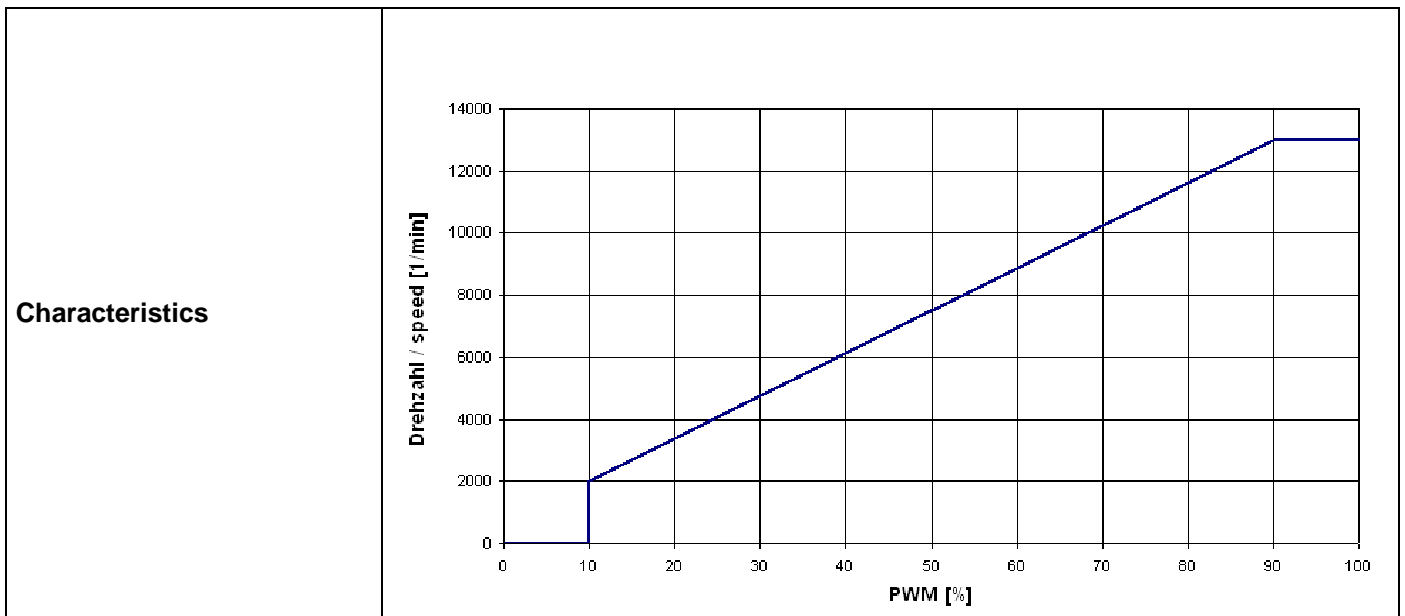

Lüfter / Fan

Kunde / Customer

Schematics

3.2 Electrical Operating Data

Measurement conditions: Normal air density = 1,2 kg/m³; Temperature 23°C +/- 3°C; Motor axis horizontal; warm-up time before measuring 5 minutes (unless otherwise specified). In the intake and outlet area should not be any solid obstruction within 0,5 m.

$\Delta p = 0$: corresp. to free air flow (see chapter aerodynamics)
I: corresp. to arithm. mean current value

Name	Condition		
PWM 0001	PWM: 100 %;	f: 1 kHz	f: 5 kHz

Features	Condition	Symbol	Values		
Voltage range		U	20,0 V		58 V
Nominal voltage		U _N		48 V	
Power consumption	$\Delta p = 0$	P	8,5 W	50 W	50 W
Tolerance	PWM 0100		+/- 17,5 %	+/- 17,5 %	+/- 25 %
Current consumption	$\Delta p = 0$	I	400 mA	1.000 mA	900 mA
Tolerance	PWM 0010		+/- 17,5 %	+/- 17,5 %	+/- 25 %
Speed	$\Delta p = 0$	n	6.800 1/min	13.000 1/min	13.000 1/min
Tolerance	PWM 0010		+/- 12,5 %	+/- 7,5 %	+/- 3 %
Starting current consumption				3.800 mA	

3.3 Electrical Interface - Output

Tacho type	/2 (open collector)
------------	---------------------

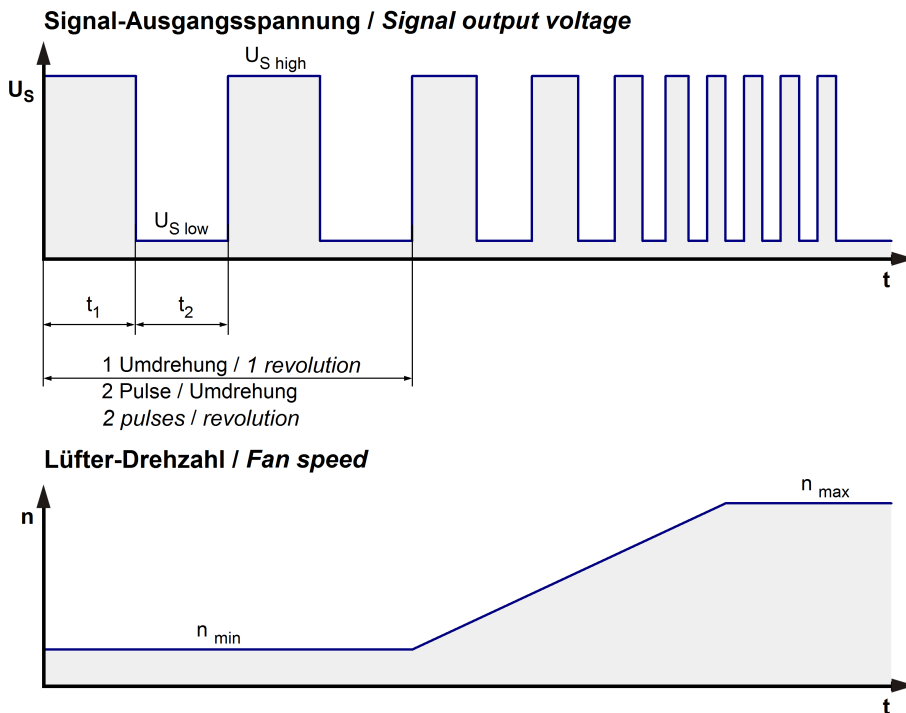

$$R_a = \frac{U_{BS} - U_{S\ low}}{I_{sink}}$$

Lüfter / Fan Kunde / Customer

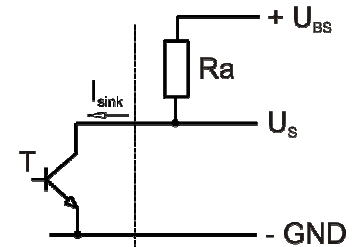

Features	Note	Values
Tacho operating voltage	U_{BS}	$\leq 60\ V$
Tacho signal Low	$U_{S\ low}$	$\leq 0,4\ V$
Tacho signal High	$U_{S\ high}$	$\leq 60\ V$
Maximum sink current	I_{sink}	$\leq 4\ mA$
External resistor	External resistor R_a from U_{BS} to U_s required. All voltages measured to GND.	
Tacho frequency	$(2 \times n) / 60$	
Tacho isolated from motor	No	
Slew rate		$\Rightarrow 0,5\ V/\mu s$

n = revolutions per minute (1/min)

3.4 Electrical Features

Electronic function	Speed-Controlled	
Reversed polarity protection	Rectifying diode	
Max. residual current at U_N	$I_F \leq 200 \mu A$	
Locked rotor protection	Auto restart	
Locked rotor current at U_N	I_{block} approx. 3.800 mA	
Clock signal at locked rotor	t_3 / t_4 typical: 0,5 s / 10 s	

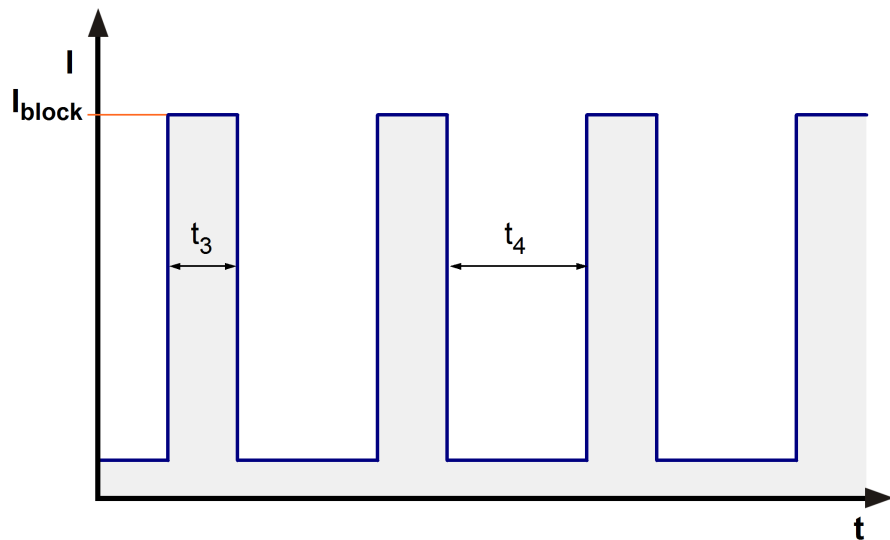

3.5 Aerodynamics

Measurement conditions: Measured with a double chamber intake rig acc. to DIN EN ISO 5801.
Normal air density = 1,2 kg/m³; Temperature 23°C +/- 3°C;
In the intake and outlet area should not be any solid obstruction within 0,5 m. Motor shaft horizontal.
The information is only valid under the specified test conditions and may be changed by the installation conditions. If there are deviations from the standard test conditions, the characteristic values must be checked under the installed conditions.

a.) Operation condition:

13.000 1/min at free air flow	PWM 100 %;	f: 1 kHz	f: 5 kHz
-------------------------------	------------	----------	----------

Max. free-air flow ($\Delta p = 0 / \dot{V} = \text{max.}$)	285,0 m ³ /h	
Max. static pressure ($\Delta p = \text{max.} / \dot{V} = 0$)	800 Pa	

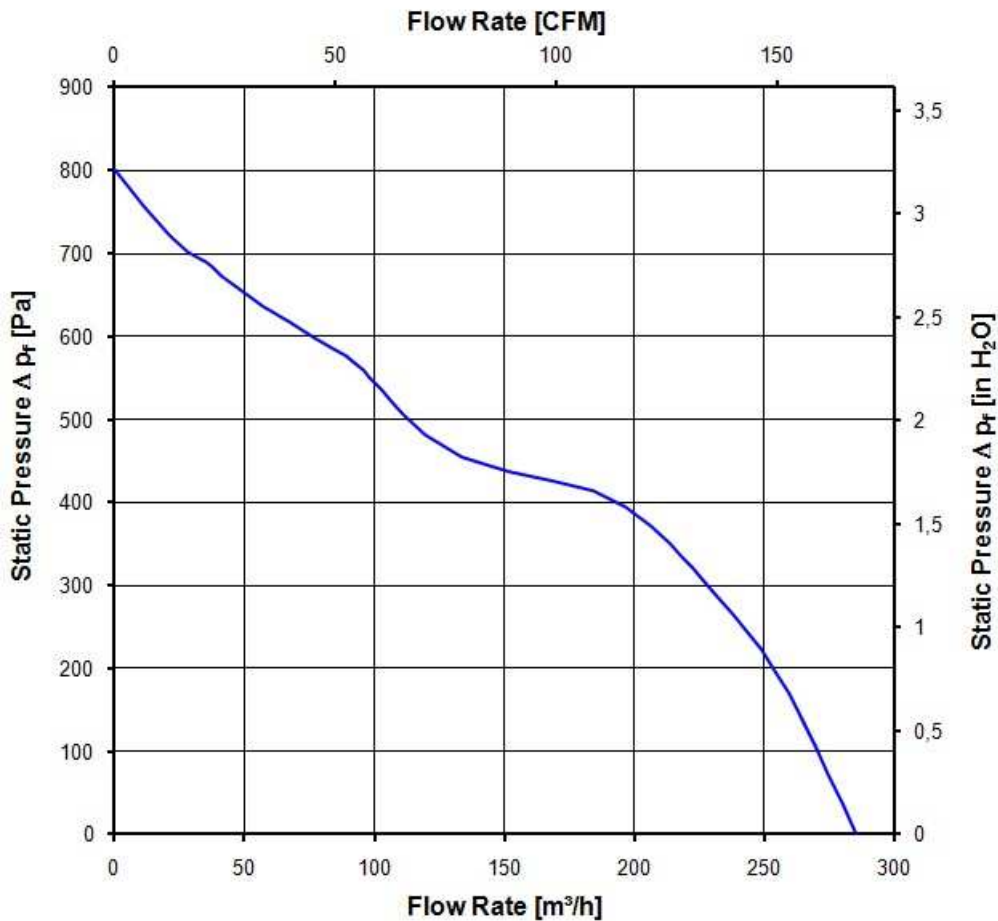

3.6 Sound Data

Measurement conditions: Sound pressure level: 1 meter distance between microphone and the air intake.
Sound power level: Acc. to DIN 45635 part 38 (ISO 10302)
Measured in a semianchoic chamber with a background noise level of $L_p(A) < 5 \text{ dB(A)}$
For further measurement conditions see chapter aerodynamics.

a.) Operation condition:

13.000 1/min at free air flow	PWM 100 %;	f: 1 kHz	f: 5 kHz
-------------------------------	------------	----------	----------

Optimal operating point	190,0 m ³ /h @ 374 Pa	
Sound power level at the optimal operating point	8,0 bel(A)	
Sound pressure level at free air flow, measured in rubber bands	76,0 dB(A)	

4 Environment

4.1 General

Min. permitted ambient temperature TU min.	-20 °C	
Max. permitted ambient temperature TU max.	70 °C	
Min. permitted storage temperature TL min.	-40 °C	
Max. permitted storage temperature TL max.	80 °C	

4.2 Climatic Requirements

Humidity requirements	humid heat, constant; according to DIN EN 60068-2-78, 14 days	
Water exposure	None	
Dust requirements	None	
Salt fog requirements	None	

Permitted application area:

The product is intended for use in sheltered rooms with controlled temperature and controlled humidity. Directly exposure to water must be avoided.

Pollution degree 1 (according DIN EN 60664-1)

There is either no pollution or it occurs only dry, non-conductive pollution. The pollution has no negative impact.

Please require severity levels and specification parameters from the responsible development departments.

5 Safety

5.1 Electrical Safety

Dielectric strength DIN EN 60950 (VDE 0805) and DIN EN 60335 (VDE 0700) A.) Type test Measuring conditions: After 48h of storage at 95% R.H. and 25°C. No arcing or breakdown is allowed! All connections together to ground.	500 VAC / 1 Min.	
B.) Routine test Measuring conditions: At indoor climate. No arcing or breakdown is allowed! All connections together to ground.	850 VDC / 1 Sec.	
Isolation resistance Measuring conditions: After 48h of storage at 95% R.H. and 25°C measured with U=500 VDC for 1 min.	RI > 10 MOhm	
Clearance / creepage distance	1,0 mm / 1,5 mm	
Protection class	III	

5.2 Approval Tests

CE	EC Declaration of Conformity	Yes
EAC	Eurasian Conformity	Yes
UL	Underwriters Laboratories	Yes / UL507, Electric Fans E38324
VDE	Association for Electrical, Electronic and Information Technologies	Yes / Approval acc. to EN 60950 (VDE 0805) - Information technology equipment
CSA	Canadian Standards Association	Yes / C22.2 No. 113 Fans and Ventilators
CCC	China Compulsory Certification	Yes / GB 12350 Safety Requirements for small Power Motors

6 Reliability

6.1 General

Life expectancy L10 at TU = 40 °C	60.000 h	
Life expectancy L10 at TU max.	30.000 h	
Life expectancy L10 acc. to IPC 9591 at TU = 40 °C	102. 500 h	

6 ± 1
verzinkt
tinned

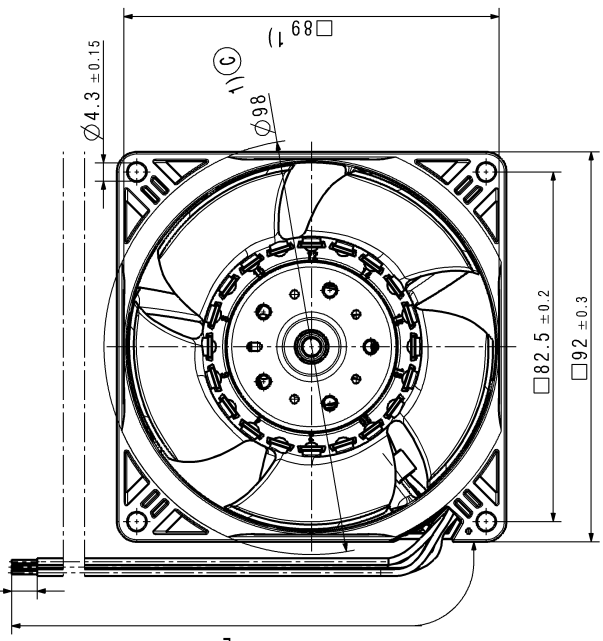

Vorderansicht
Maßstab: 1:1
front view
scale: 1:1

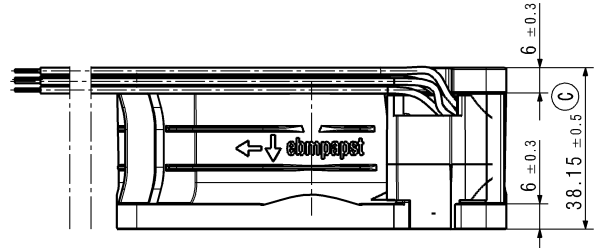

Seitenansicht links
Maßstab: 1:1
side view left
scale: 1:1

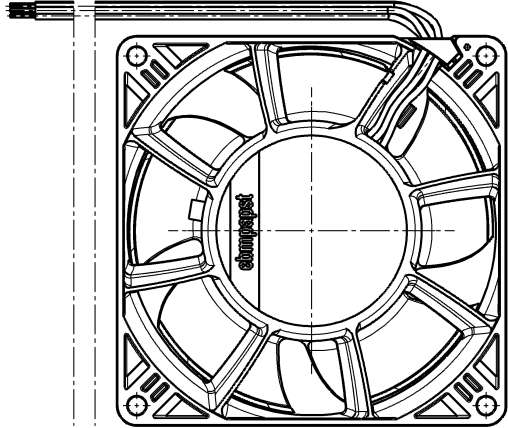

Rückansicht
Maßstab: 1:1
back view
scale: 1:1

Zeichnung entspricht 3D-Modell:
Drawing is equivalent to 3D-Model:
9693520181_CPR_000_C
System: CATIA V5 R 14

- 1) Maße für Montagewand
- 1) dimension for worktop mounting
- Anzahl und Länge der Litzen siehe Produktspezifikation
number and length of the wires, look at the product specification
- Kein Axialspiel bei Kugellager durch Federausgleich
no axial clearance of ball bearings conditional on a pre-load spring

SHWETZMARK GmbH D20 150 16018 Bauteile
Refer to production order D20 150 16018 Bauteile
Copying of this document, and giving it others and the use or communication of the contents thereof, are forbidden without express authority. Orders are liable to the patent of design. All rights are reserved in the event of the grant of a patent or the registration of a utility model or design.

BP-Status/State	Appr. Nr. / Change No.	CAD System-Version/ CAD-System-Version	CD-Instanz/ CAD-Environment	Hersteller / Material:	Volume / Volume (litre):
Toleranzung / Tolerances:	Allgemeintoleranzen / Gen. Tolerances:	Datum	Name	Artikelnr. / Title:	Stückzahl / Quantity
		Beibehalten / Keep / Preserve	Ändern / Change / Modify	Zeichn.-Nr. / Drawing No.:	Formate / Size:
		ebmpapst		Einheit / Unit:	Massstab/Scale
		ebmpapst St. Georgen aub. & Co KG		Einheit / Unit:	Formate / Size: