

Product Data Sheet 3214 JH3-195

ebmpapst

Die Wahl der Ingenieure



3214 JH3-195

INDEX

1	General	3
2	Mechanics	3
2.1	General	3
2.2	Connections	3
3	Operating Data	5
3.1	Operating Data - Electrical Interface - Input	5
3.2	Electrical Operating Data	6
3.3	Operating Data - Electrical Interface - Output	7
3.4	Electrical Features	7
3.5	Aerodynamics	8
3.6	Sound Data	9
4	Environment	9
4.1	General	9
4.2	Climatic Requirements*)	9
5	Safety	10
5.1	Electrical Safety	10
5.2	Approval Tests	10
6	Reliability	10
6.1	General	10

1 General

Fan type	Fan	
Rotating direction looking at rotor	Clockwise	
Airflow direction	Air outlet over struts	
Bearing system	Ball bearing	
Mounting position	Any	

2 Mechanics**2.1 General**

Width	92,0 mm	
Height	92,0 mm	
Depth	38,0 mm	
Mass	0,240 kg	
Housing material	Plastic	
Impeller material	Plastic	
Max. torque when mounted across both mounting flanges	wire outlet corner: 30 Ncm remaining corners: 30 Ncm	
Screw size	ISO 4762 - M4 degreased, without an additional brace and without washer	

2.2 Connections

Electrical connection	Wires	
Lead wire length	L = 310 mm	
Tolerance	+ - 10,0 mm	
Wire size (AWG)	24	
Insulation diameter	1,55 mm	
Contact	See drawing	

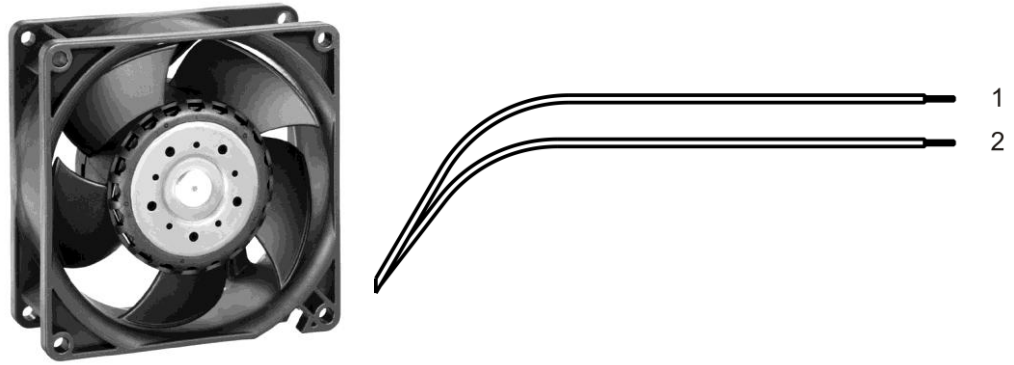

	Colour	Operation
Wire 1	red	+ UB
Wire 2	blue	- GND

3 Operating Data

3.1 Operating Data - Electrical Interface - Input

Control input	None
---------------	------

3.2 Electrical Operating Data

Measurement conditions: Normal air density = 1,2 kg/m³; Temperature 23°C +/- 3°C; Motor axis horizontal; warm-up time before measuring 5 minutes (unless otherwise specified). In the intake and outlet area should not be any solid obstruction within 0,5 m.

$\Delta p = 0$: corresp. to free air flow (see section 3.5)
 I: corresp. to arithm. mean current value

Features	Condition	Symbol	Values		
Voltage range	$\Delta p = 0$	U	20,0 V		26,0 V
Nominal voltage	$\Delta p = 0$	U_N		24,0 V	
Power consumption	$\Delta p = 0$	P	20,0 W	28,3 W	31,2 W
Tolerance	0001		+/- 18,0 %	+/- 25,0 %	+/- 25,0 %
Current consumption	$\Delta p = 0$	I	1.000 mA	1.180 mA	1.200 mA
Tolerance	0001		+/- 18,0 %	+/- 25,0 %	+/- 25,0 %
Speed	$\Delta p = 0$	n	9.250 1/min	10.500 1/min	10.500 1/min
Tolerance	0001		+/- 13,0 %	+/- 3,0 %	+/- 3,0 %
Starting current consumption				<= 5.000 mA	

3.3 Operating Data - Electrical Interface - Output

Tacho type	None
------------	------

Alarm type	None
------------	------

3.4 Electrical Features

Electronic function	Speed-Controlled	
Reversed polarity protection	Rectifying diode	
Max. residual current at Un	IF ≤ 10 mA	
Locked rotor protection	Auto restart	
Locked rotor current at Un	approx. 3.500 mA	
Clock signal t3/t4 at locked rotor	Typical: 0,3 s / 10,0 s	

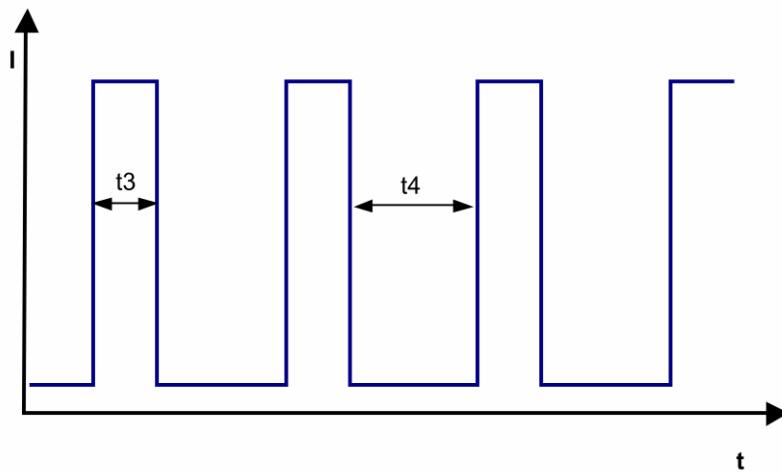

3.5 Aerodynamics

Measurement conditions: Measured with a double chamber intake rig acc. to DIN EN ISO 5801.
 Normal air density = 1,2 kg/m³; Temperature 23°C +/- 3°C;
 In the intake and outlet area should not be any solid obstruction within 0,5 m.
 The information is only valid under the specified test conditions and may be changed by the installation conditions. If there are deviations from the standard test conditions, the characteristic values must be checked under the installed conditions.

a.) Operation condition:

10.500 1/min at free air flow

Max. free-air flow ($\Delta p = 0 / \dot{V} = \text{max.}$)	230,0 m ³ /h	
Max. static pressure ($\Delta p = \text{max.} / \dot{V} = 0$)	550 Pa	

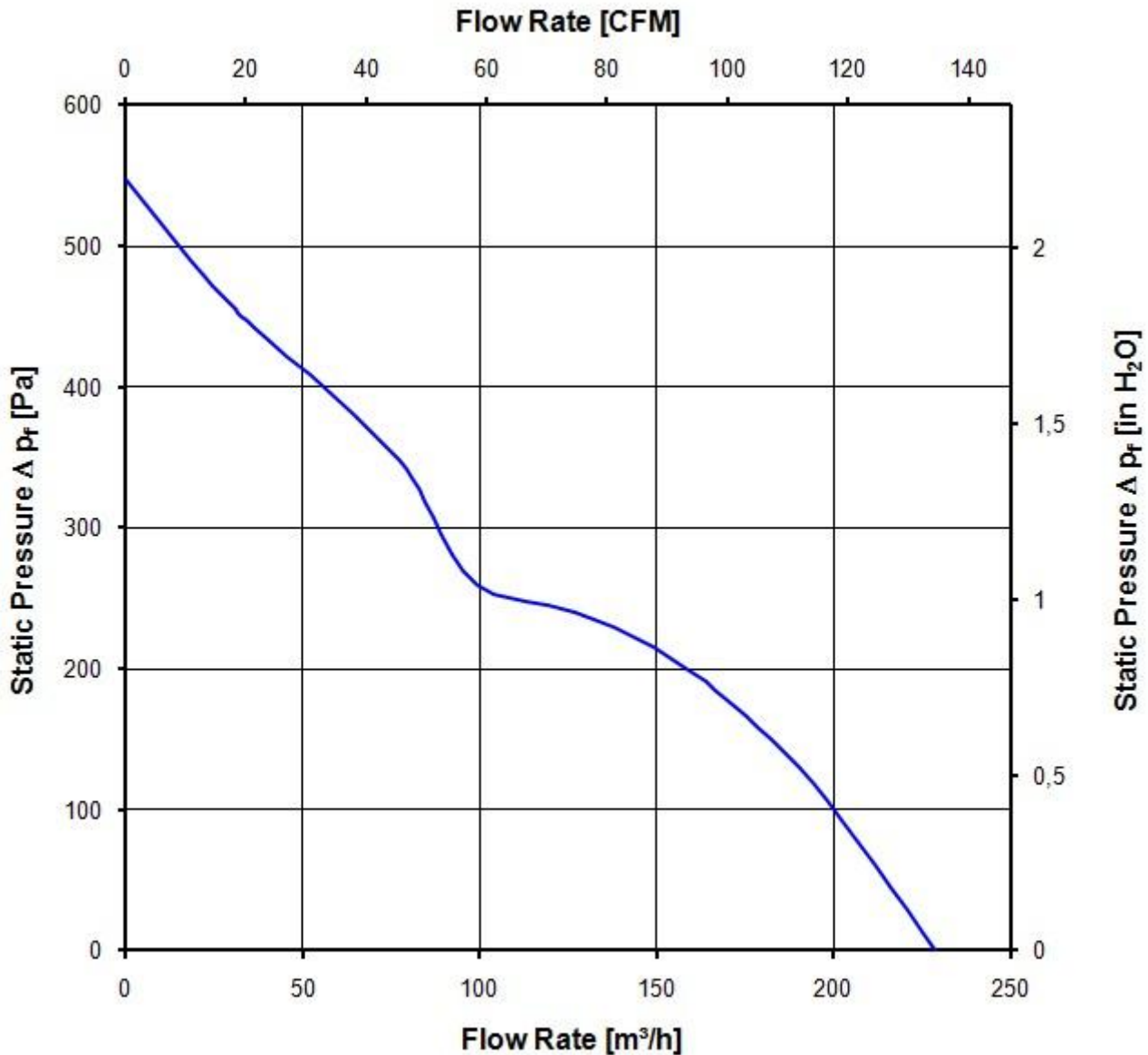

3.6 Sound Data

Measurement conditions: Sound pressure level: 1 Meter distance between microphone and the air intake.
 Sound power level: Acc. to DIN 45635 part 38 (ISO 10302)
 Measured in a semianchoic chamber with a background noise level of $L_p(A) < 5 \text{ dB(A)}$
 For further measurement conditions see section 3.5

a.) Operation condition:

10.500 1/min at free air flow

Optimal operating point	120,0 m3/h @ 218 Pa	
Sound power level at the optimal operating point	7,5 bel(A)	
Sound pressure level at free air flow, measured in rubber bands	66,0 dB(A)	

4 Environment

4.1 General

Min. permitted ambient temperature TU min.	-20 °C	
Max. permitted ambient temperature TU max.	55 °C	
Min. permitted storage temperature TL min.	-40 °C	
Max. permitted storage temperature TL max.	80 °C	

4.2 Climatic Requirements *)

Humidity requirements	humid heat, constant; according to DIN EN 60068-2-78, 14 days	
Water exposure	None	
Dust requirements	None	
Salt fog requirements	None	

*) Permitted application area:

The product is intended for use in sheltered rooms with controlled temperature and controlled humidity. Directly exposure to water must be avoided.

Pollution degree 1 (according DIN EN 60664-1)

There is either no pollution or it occurs only dry, non-conductive pollution. The pollution has no negative impact.

Please require severity levels and specification parameters from the responsible development departments

5 Safety

5.1 Electrical Safety

Dielectric strength DIN EN 60950 (VDE 0805) and DIN EN 60335 (VDE 0700) A.) Type test Measuring conditions: After 48h of storage at 95% R.H. and 25°C. No arcing or breakdown is allowed! All connections together to ground.	500 VAC / 1 Min.	
B.) Routine test Measuring conditions: At indoor climate. No arcing or breakdown is allowed! All connections together to ground.	500 VAC / 1 Sec.	
Isolation resistance Measuring conditions: After 48h of storage at 95% R.H. and 25°C measured with U=500 VDC for 1 min.	RI > 10 MOhm	
clearance / creepage distance	1,0 mm / 1,2 mm	
Protection class	III	

5.2 Approval Tests

CE	EC Declaration of Conformity	Yes
EAC	Eurasian Conformity	Yes
UL	Underwriters Laboratories	Yes / UL507, Electric Fans
VDE	Association for Electrical, Electronic and Information Technologies	No
CSA	Canadian Standards Association	Yes / CSA audited by UL according to C22.2 No. 113 Fans and Ventilators
CCC	China Compulsory Certification	No

6 Reliability

6.1 General

Life expectancy L10 at TU = 40 °C	45.000 h	
Life expectancy L10 at TU max.	30.000 h	

Copying of this document, and giving it to others and the use or communication of the contents thereof, are prohibited without the written consent of the copyright holder. All rights are reserved in the event of the grant of a patent, or the registration of a utility model or design.

Schutzvermerk nach DIN ISO 8016 beachten

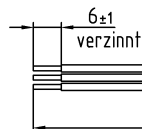
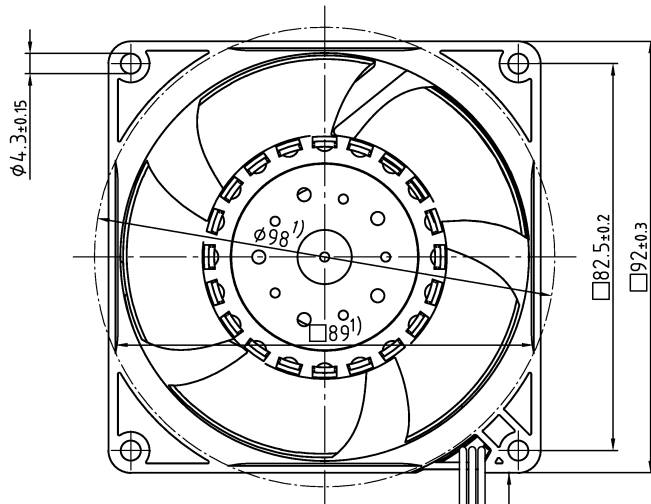
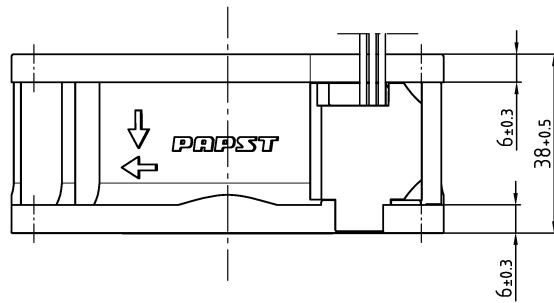

Anzahl und Länge der Litzen
siehe Bv - Bl.1

Axialspiel bei
- Kugellagerung (K): 0 (mit Federausgleich)
- Gleitlagerung (G): 0.1 - 1.6

1) Maße für Montagewand

Tolerierung: DIN 7167
Allgemeintoleranzen:

DIN ISO 2768-mK-E

	Datum	Name
Bearbeitet		
	Index	Aend.-Nr.
Geprüft u. zur Verwendung freigegeben von		am

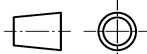

PAPST
PAPST-MOTOREN GmbH & Co KG
D-78112 St. Georgen
Germany

Artikel	Maßstab
Zchg.-Nr.	Blatt
Ers.f.Zchg.	A4